

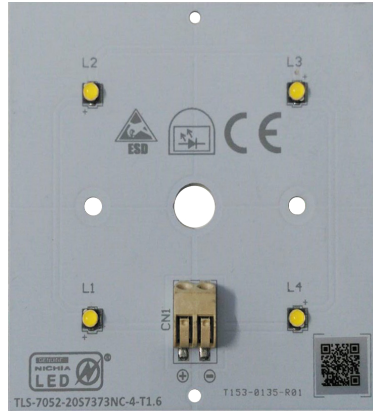

## PRODUCT PHOTO



## SPECIFICATIONS

- Default driving method is constant current input.
- CCT Range from 2000°K up to 6500°K
- Luminous flux range from 677 lm to 2222 lm
- Efficacy of the module up to 164 lm/W
- CRI 70 is standart, CRI 80 and CRI 90 are available
- Outstanding system color tolerance MacAdam 3 over the full operating area
- Simple installation
- Long life-time > 60,000 hours
- 5 years guarantee at specified conditions



For your orders please call us:

**+90 444 27 33**

## APPLICATIONS



Interior  
Architectural  
Lighting

Flood Light

## PHOTOMETRY

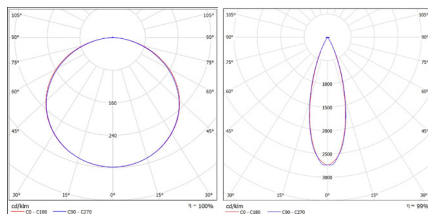

W/O LENS

LEDIL FLORENTI-  
NA-2X2-SHD





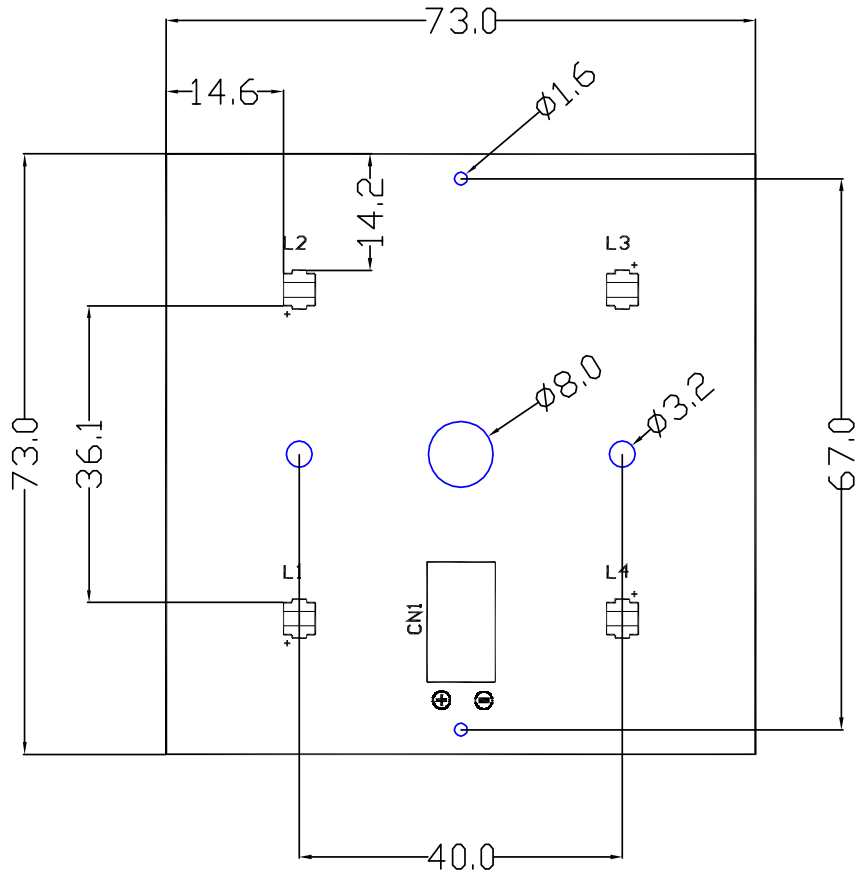

## X-MS7373NC50-NVSW319AT-4 MECHANICAL DRAWINGS



SERBEST ÖLÇÜ TOLERANSLARI -DIN 2768-1 / General Tolerances for linear and angular dimensions (DIN ISO 2768-1)

0.5 up to 3mm	± 0.1	over 3 up to 6mm	± 0.1	over 6 up to 30mm	± 0.2	over 30 up to 120mm	± 0.3	over 120 up to 400mm	± 0.5	over 400 up to 1000mm	± 0.8
---------------	-------	------------------	-------	-------------------	-------	---------------------	-------	----------------------	-------	-----------------------	-------

Stock code No : 3970	MALZEME (MATERIAL) PC	AGIRLIK (WEIGHT)	 ÖLÇEK / SCALE A4
Revision : 00	PARÇA NO (PART NO) TLS-7052-20S7373NC-4-T1.6		
Date : 17.11.2017			 <b>TD Lighting Solutions</b>
Sheet : 1			
Drawn By : M. KAZAKLI			
Checked By : D. SANATSEVER			
Approved By : M. CINAR			

TLS Teknoloji Sanayi ve Dis Ticaret A.S. This drawing is our property. It cant be reproduced or communicated without our written agreement.

CCT AND BINNING INFORMATION

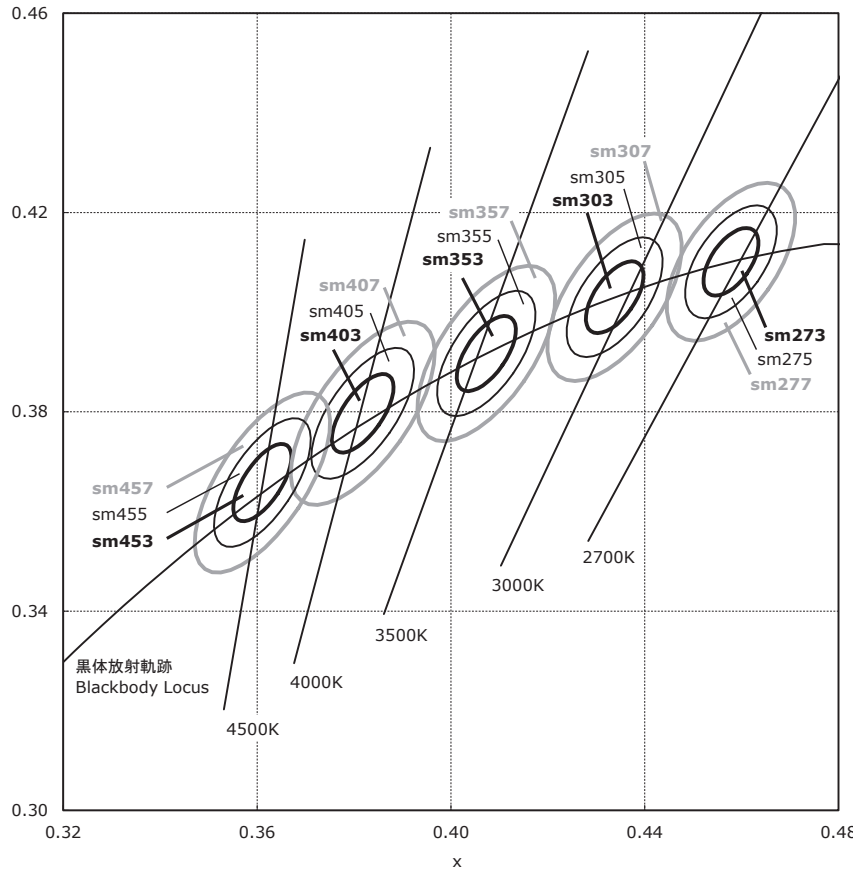

## LIFETIME PROJECTION & WORST CONDITION PERFORMANCE

MODEL NUMBER: **NVSW319A**

### Test Summary:

Data Set	Case Temperature [T <sub>s</sub> ]	Ambient Temperature [T <sub>A</sub> ]	Drive Current [I <sub>r</sub> ]	Lumen Maintenance at 10,000 hours	Chromaticity Shift (Δu'v')	TM-21 Projection L <sub>70</sub> (10K)	TM-21 Projection L <sub>80</sub> (10K)	TM-21 Projection L <sub>90</sub> (10K)
1	55 °C	> 50 °C	700 mA	99.0 %	0.0015	> 60000 hours	> 60000 hours	> 60000 hours
2	55 °C	> 50 °C	1500 mA	98.1 %	0.0016	> 60000 hours	> 60000 hours	> 60000 hours
3	85 °C	> 80 °C	700 mA	98.5 %	0.0014	> 60000 hours	> 60000 hours	> 60000 hours
4	85 °C	> 80 °C	1200 mA	98.1 %	0.0018	> 60000 hours	> 60000 hours	> 60000 hours
5	85 °C	> 80 °C	1500 mA	97.9 %	0.0021	> 60000 hours	> 60000 hours	> 60000 hours
6	105 °C	> 100 °C	700 mA	97.7 %	0.0019	> 60000 hours	> 60000 hours	> 60000 hours
7	105 °C	> 100 °C	1200 mA	97.5 %	0.0025	> 60000 hours	> 60000 hours	> 60000 hours
8	105 °C	> 100 °C	1500 mA	97.0 %	0.0030	> 60000 hours	> 60000 hours	50900 hours
9	120 °C	> 115 °C	1200 mA	95.5 %	0.0041	> 60000 hours	> 60000 hours	30000 hours

Data Set 6 : 105°C, 120mA

Test Duration used	0-6000 hrs
B	1,0107
α	2,0007E-01

Curve-fit equation:  
 $\Phi(t)=Bexp(-at)$

Lumen maintenance life equation:  
 $L_{70} = \ln(B/0.7)/\alpha$

## LEGAL NOTICE

Product information provided by TLS Teknoloji Sistemleri San ve Dış Tic AŞ ("TLS") in this document is believed to be correct and accurate. TLS reserves the right to change/correct the specifications and other data or information relating to products without notice but TLS accepts no liability for errors that may appear in this document, howsoever occurring, or liability arising from the use or application of any information or data provided herein. Neither the supply of such information, nor the purchase or use of products conveys any licence or permission under patent, copyright, trademark or other intellectual property right of TLS or third parties.

Products sold by TLS are subject to its standard Terms and Conditions of Sale that are available on request. No warranty is given that products do not infringe the intellectual property rights of third parties, and furthermore, the use of products in certain ways or in combination with TLS, or non-TLS furnished equipments/components may infringe intellectual property rights of TLS.

The purpose of this document is to provide information only and it may not be used, applied or reproduced (in whole or in part) for any purpose nor be taken as a representation relating to the products in question. No warranty or guarantee express or implied is made concerning the capability, performance or suitability of any product, and information concerning possible applications or methods of use is provided for guidance only and not as a recommendation. The user is solely responsible for determining the performance and suitability of the product in any application and checking that any specification or data it seeks to rely on has not been superseded.

Products are intended for normal commercial applications. For applications requiring unusual environmental requirements, extended temperature range, or high reliability capability (e.g. military, or medical applications), special processing/testing/conditions of sale may be available on application to TLS.

## CONTACT

### **TLS Teknoloji Sistemleri San ve Dış Tic AŞ**

Akçaburgaz Mahallesi 3080. Sokak No:5 Esenyurt / İstanbul / TURKEY

info@tsteknoloji.com  
+90 444 27 33